

# Open Club Klimmen

Terugkoppeling

13-11-2019



ONTWIKKEL SAMEN  
**OPEN-CLUB**

 **RO groep**  
van waardevol  
naar waardevast

# Agenda



1. Welkom door wethouder Ruud Braun

1. Stand van zaken project OCK  
Ontwikkelplan (gebouw en buitenruimte)  
Aanvullende besluitvorming  
Bouworganisatievorm

2. Stedenbouwkundige en landschappelijke kaders  
Analyse opgave en bestaand gebied  
Kaders

3. Interactief gedeelte

4. Plenaire afsluiting  
Punten die zijn opgehaald deze avond  
Planning OCK



# Ontwikkelplan

*Afrouding definitiefase*



Onderdelen ontwikkelplan:

- Visie, ruimtprogramma, PVE voor het gebouw
- Uitgangspunten Beheer en exploitatie
- **Visie en programma totaal 'buiten'**  
met kaders voor verkeer, parkeren, landschap, groen, water, bodem, gebouwen voetbal en tennis, etc.
- **Plankader voor stedenbouw en landschap**
- Keuze bouworganisatievorm
- Financieel plan



# Gebouw en de vaste gebruikers

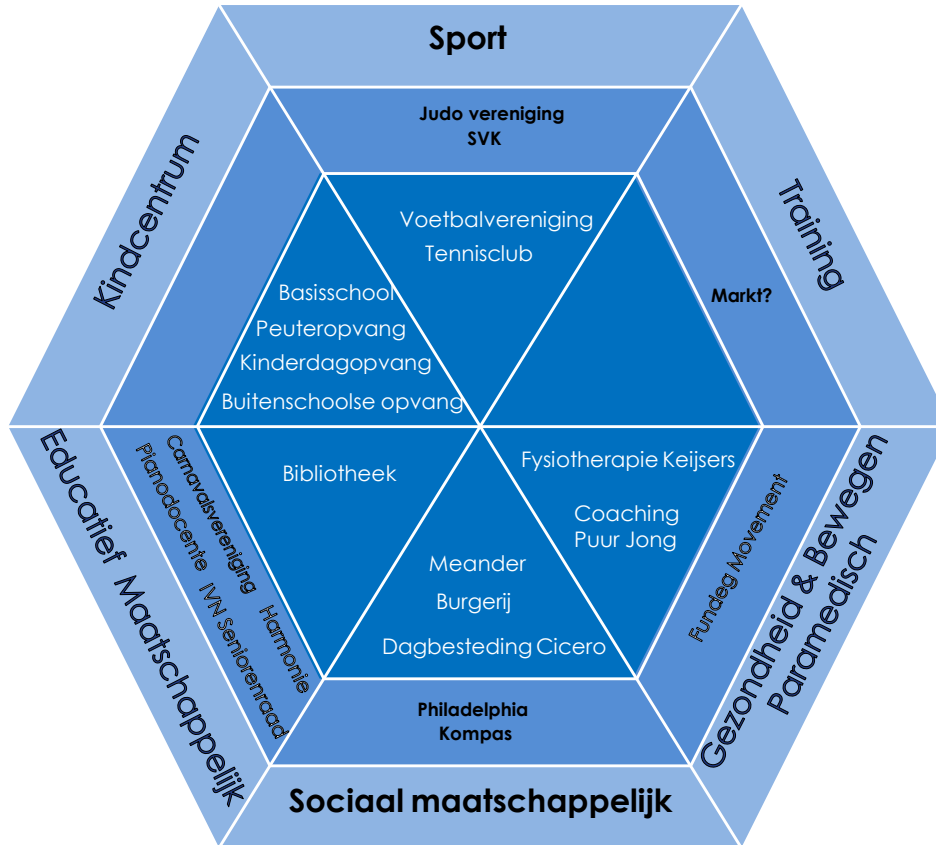



# Gebouw ruimteprogramma

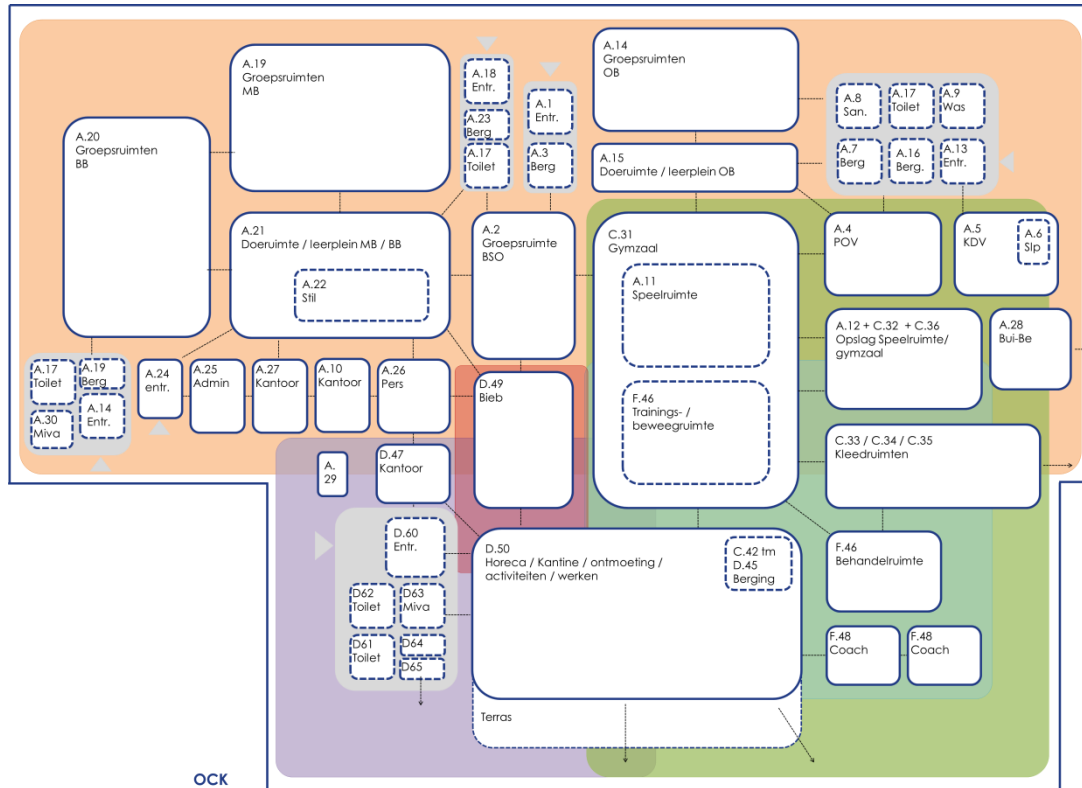

## Gebouw

2.755 m<sup>2</sup> bvo

- Visie
- Ruimteprogramma
- Technisch PVE

# Aanvullende besluitvorming en bouworganisatievorm

- Ivm hogere investeringskosten aanvullende besluitvorming door de gemeenteraad (februari 2020).
- Daarna aanbesteding integraal ontwerp
- Op basis van PVE integraal ontwerp van gebouw en buitenruimte
  - Complexe landschappelijke en stedenbouwkundige opgave, ambities duurzaamheid en klimaatbestendigheid.
  - Mogelijkheden voor bijsturen door opdrachtgever en gebruikers.
- Na voorlopig ontwerp verder in bouwteamverband
  - Technisch ontwerp gebouw, daarna contractvorming met aannemer.

Stedenbouwkundige  
en  
landschappelijke  
kaders



# Plangebied



# Masterplan als vertrekpunt



1. collectieve entree en parkeerplaats 120 voertuigen
2. centraal gebouw open club
3. groene centrale ontmoetingsruimte
4. vanuit centrale ontmoetingsruimte route naar tennisvelden
5. thematuinen
6. voetbalvelden met nieuwe toplaag
7. afsluiten huidige entree voor gemotoriseerd verkeer



# Inspiratiesessie 2 april 2019



# Ontwerpsessie basisschoolleerlingen 5 juni 2019

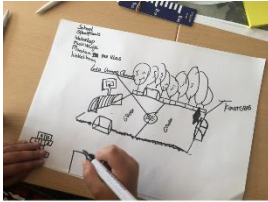

**appelboom**

**glijbaan tussen bomen door**

**crossbaan plateau in de bomen hut op de vloer**



**watertafel spelhuis klimrek multiveld klimmuur**

**zandbak insectenhotel natuurlijk hekwerk pannakooi**

**paadjes slingerend door het gebied speelbos buiten wc**

**skatebaan overdekte fietsenstalling hinkelbaan**

**moestuin aquarium trampoline onder een brug picknicktafel**

**lasergame kabelbaan boomhutten klein fossielenmuseum**

**bruggen tussen bomen tunnels dieren watertap**

**schoolplein op het dak buitenkeuken bij moestuin**

**groenteopslag**

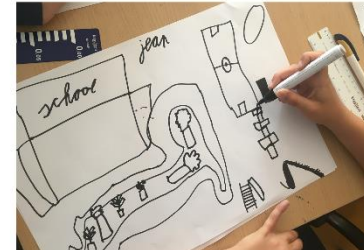
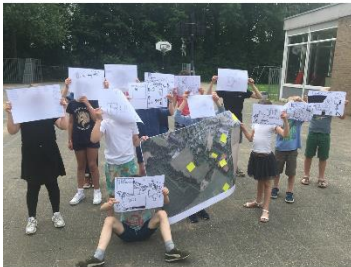
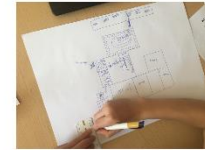
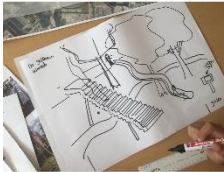



# Historie

1864





# Historie

1936

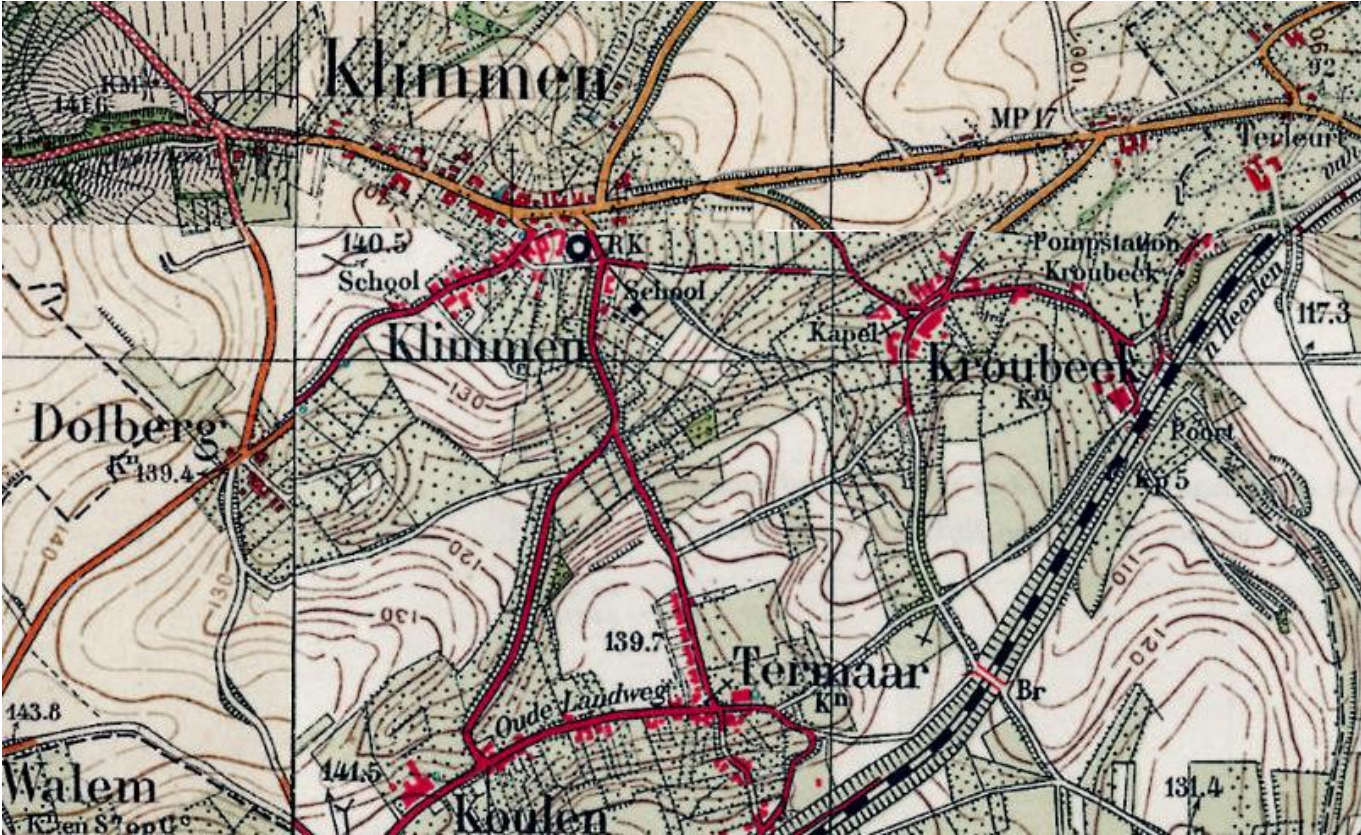



# Historie

1979

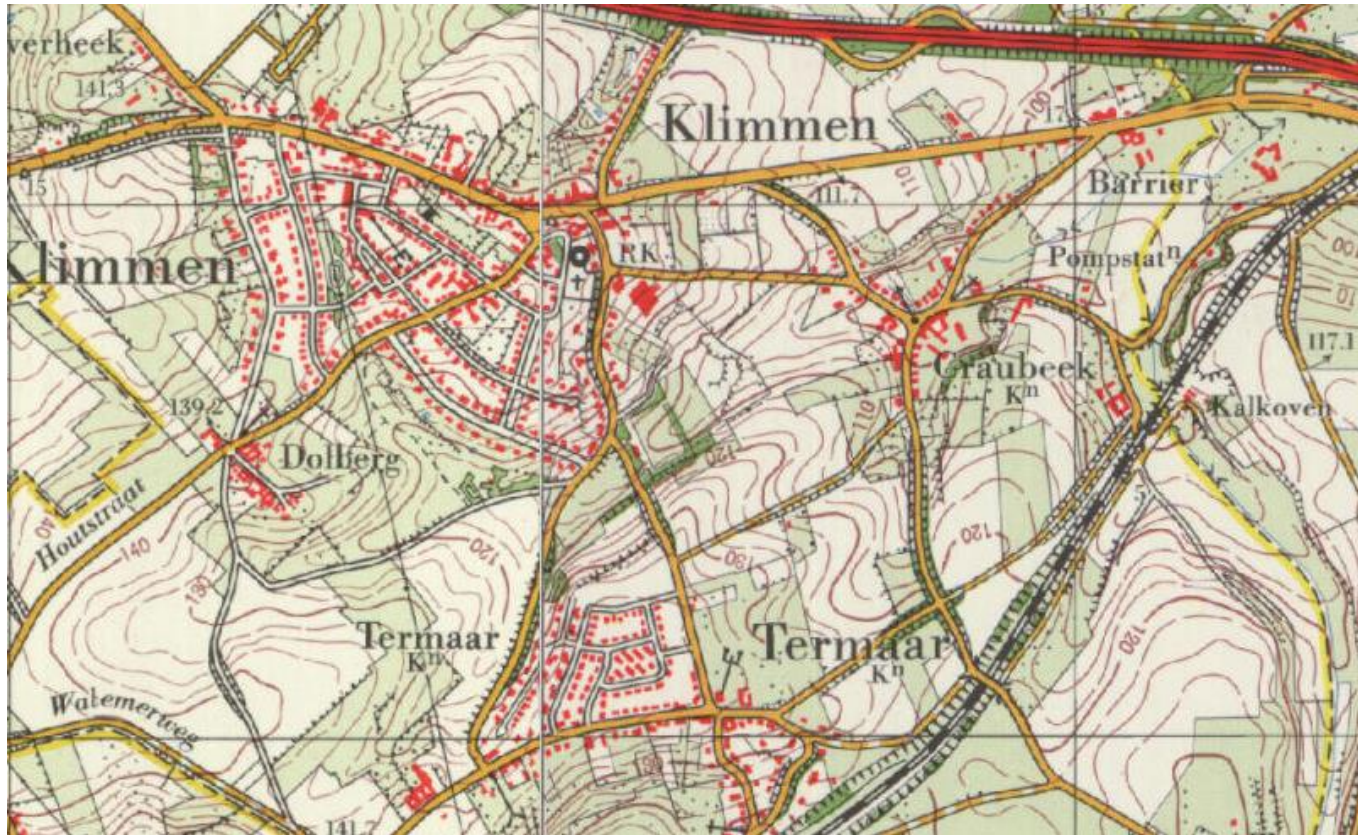



# Historie

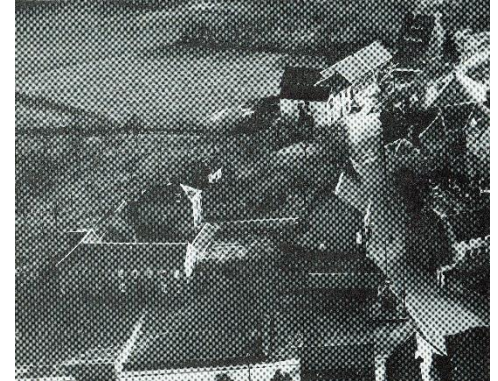



# Karakteristieken plangebied

*Groene kamers en doorzichten*



# Karakteristieke plangebied

*Sociaal maatschappelijke functies aan de groene wig*

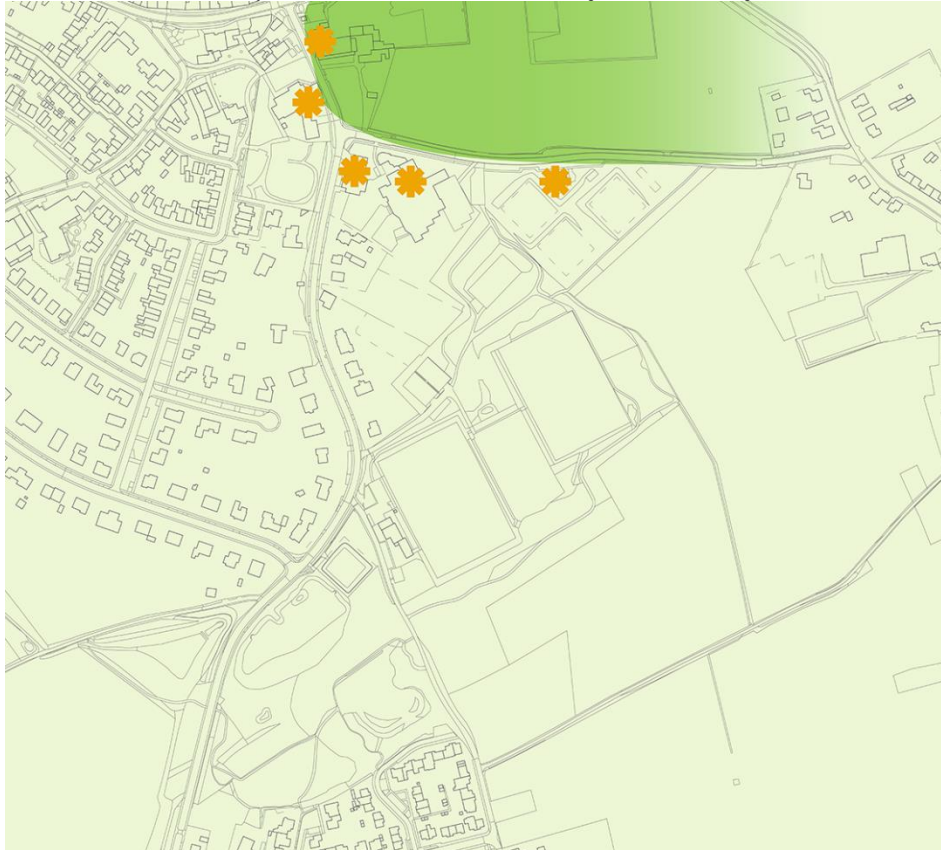



# Karakteristieken plangebied

## *Padenstructuur*



# Karakteristieken plangebied





# Karakteristieken plangebied

*Versuiperd droogdal*

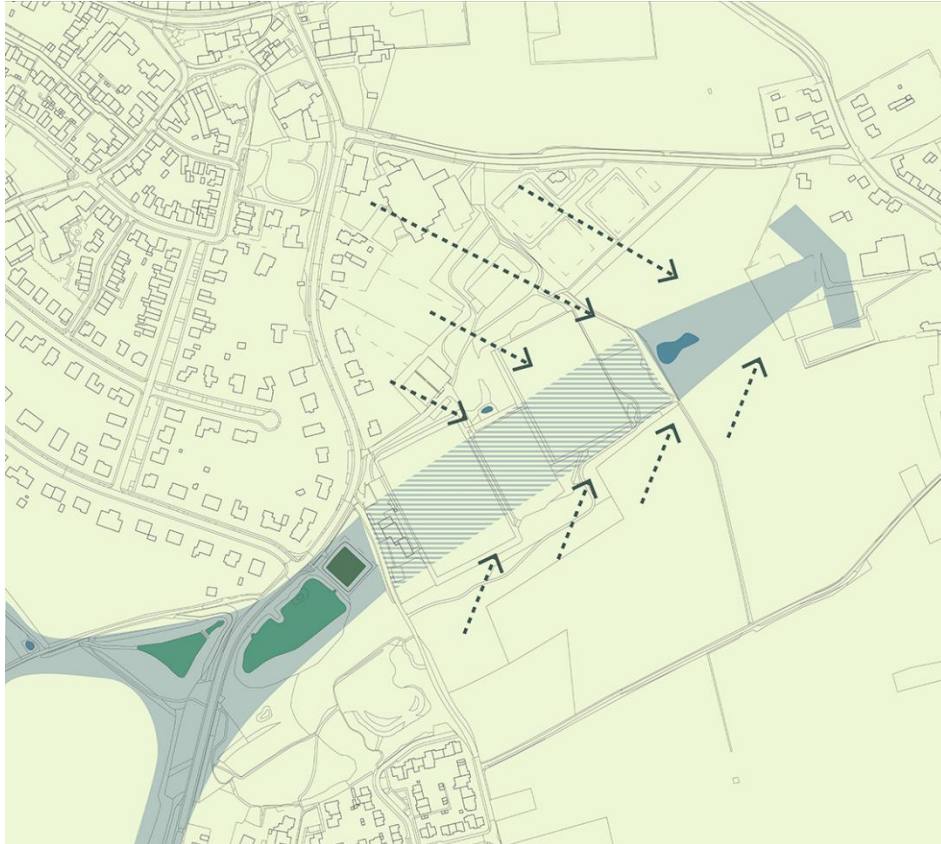



# Karakteristieken plangebied

## *Gecultiveerde inrichting*

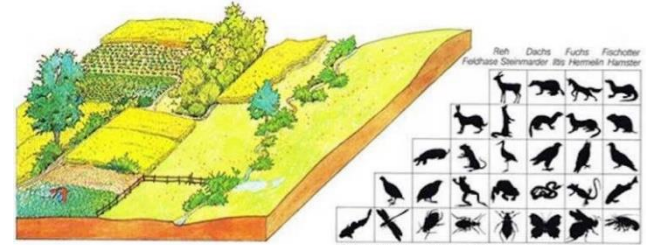

Mühlkoppe Prachtbelle Gelbrandkäfer Goldaukflücker Makflücker Tauernmarter Ackerhummel Fliegen

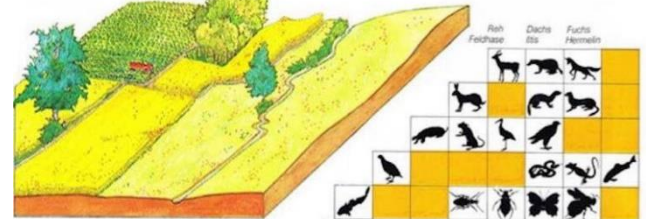

Rebhuhn Mühlkoppe Goldaukflücker Makflücker Tauernmarter Ackerhummel

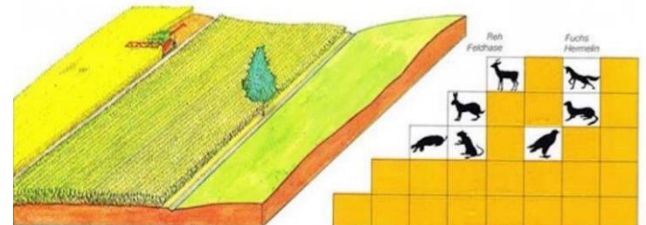

# Kaders inrichting gebied

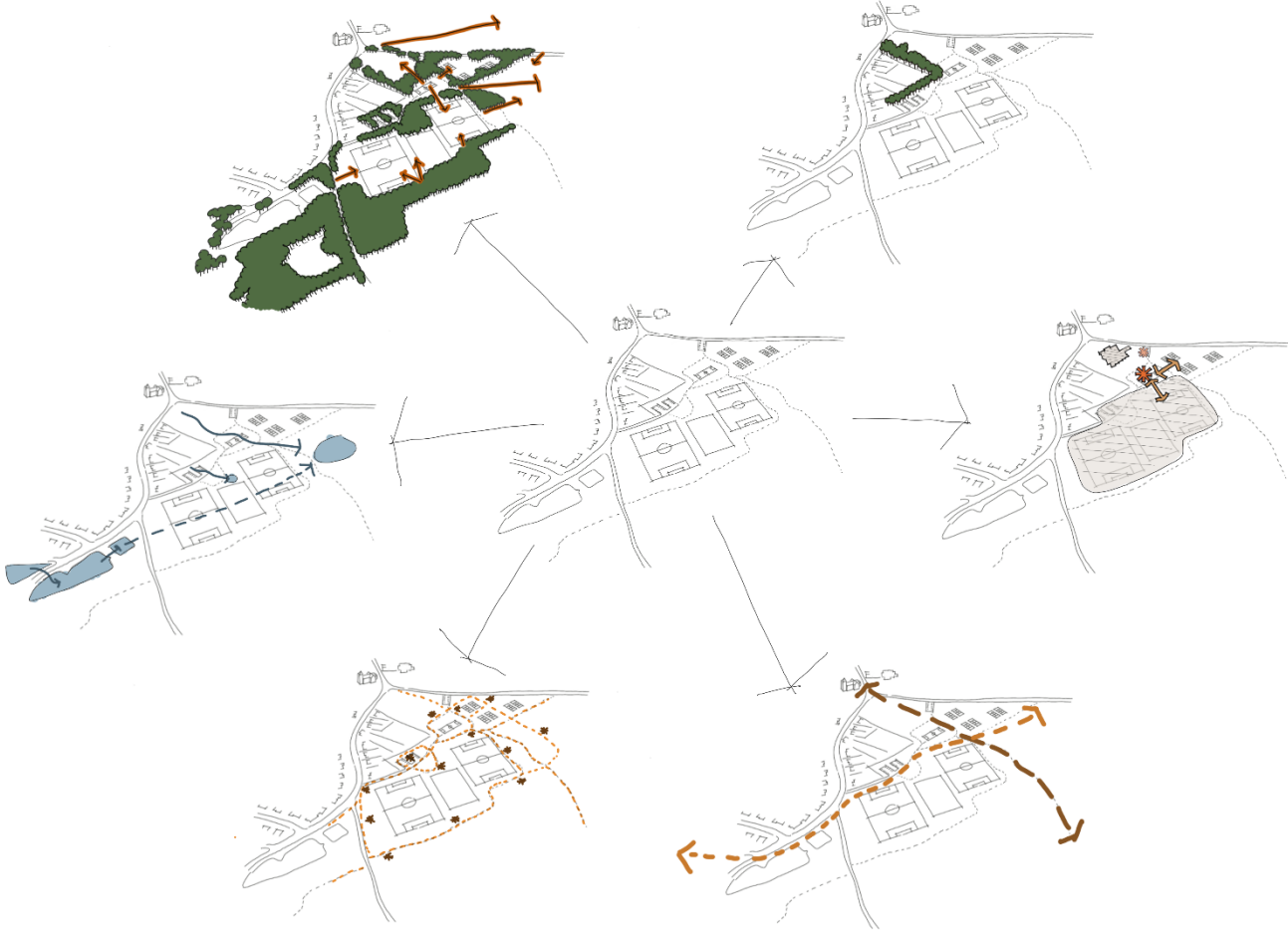

# Kaders inrichting gebied

*Behoud en versterking groene kamers met doorzichten*

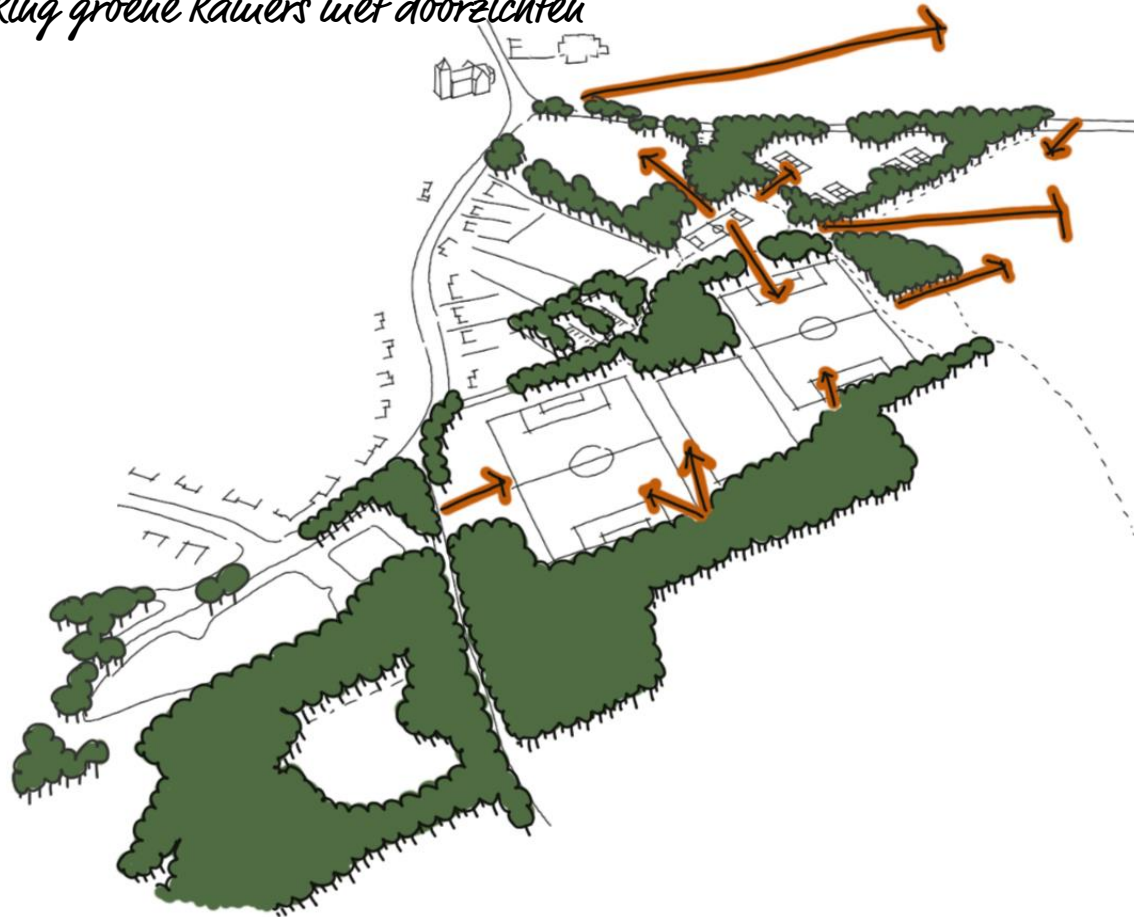

# Kaders inrichting gebied

*Groene afscherming richting woningen*

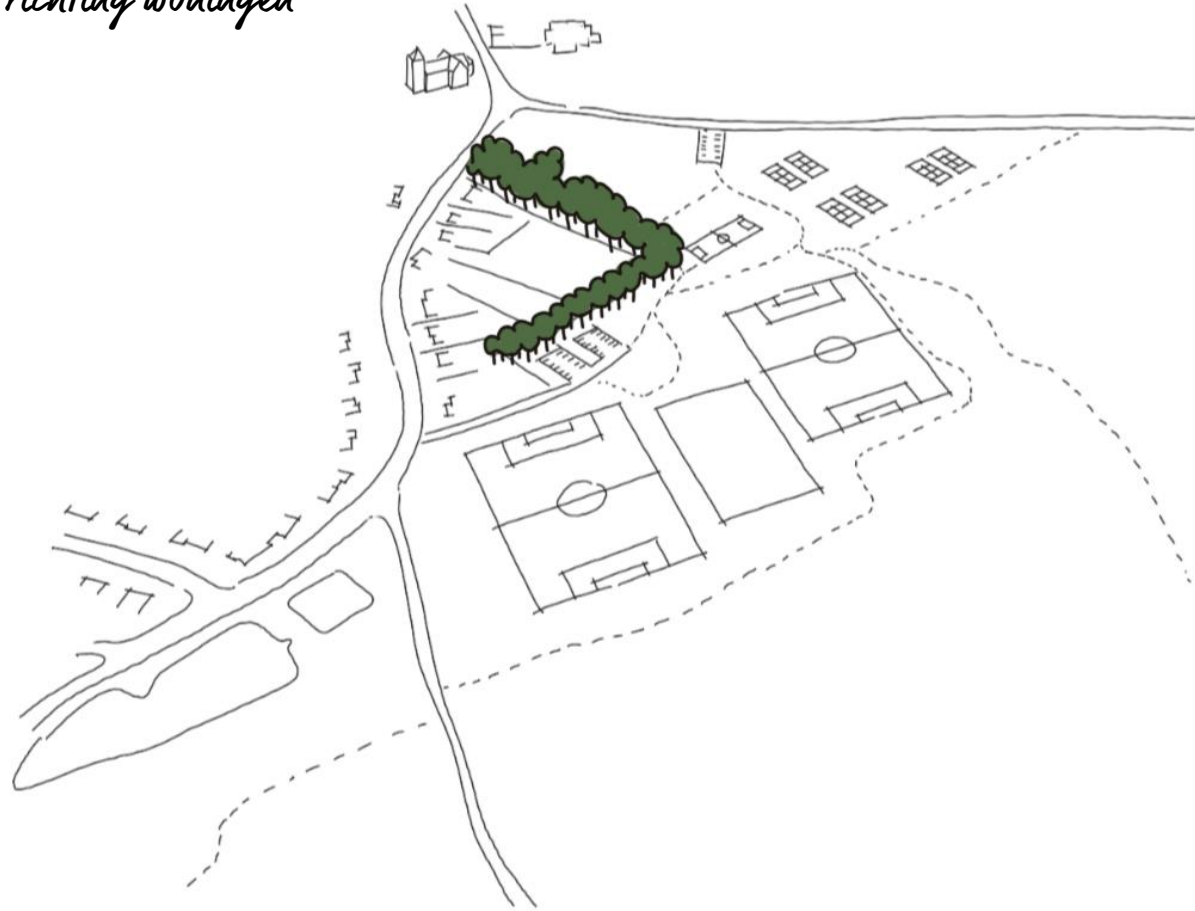



# Kaders inrichting gebied

*Centrale ligging hoofdgebouw OCK*

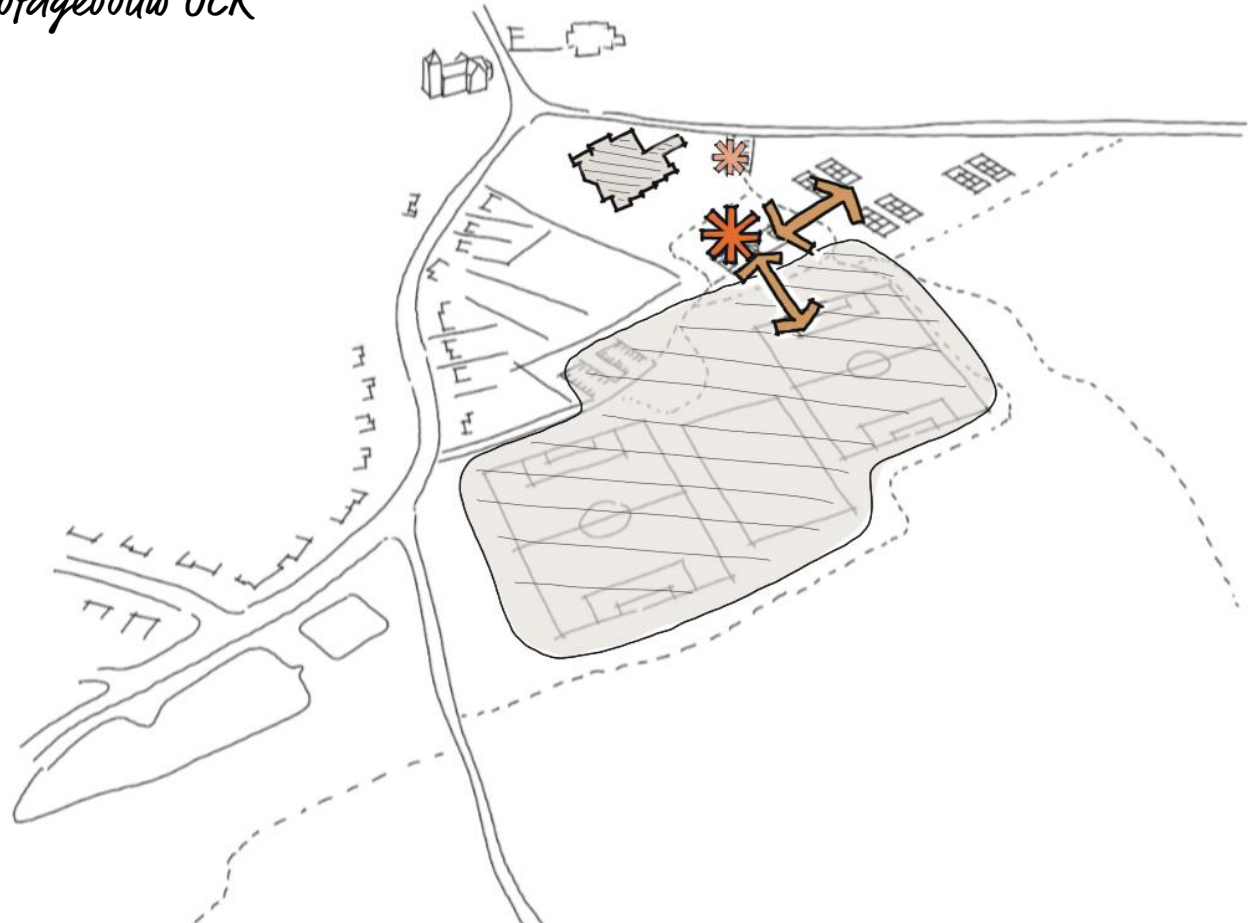

# Kaders inrichting gebied

*Zichtbare en getrapte afvoer regenwater*

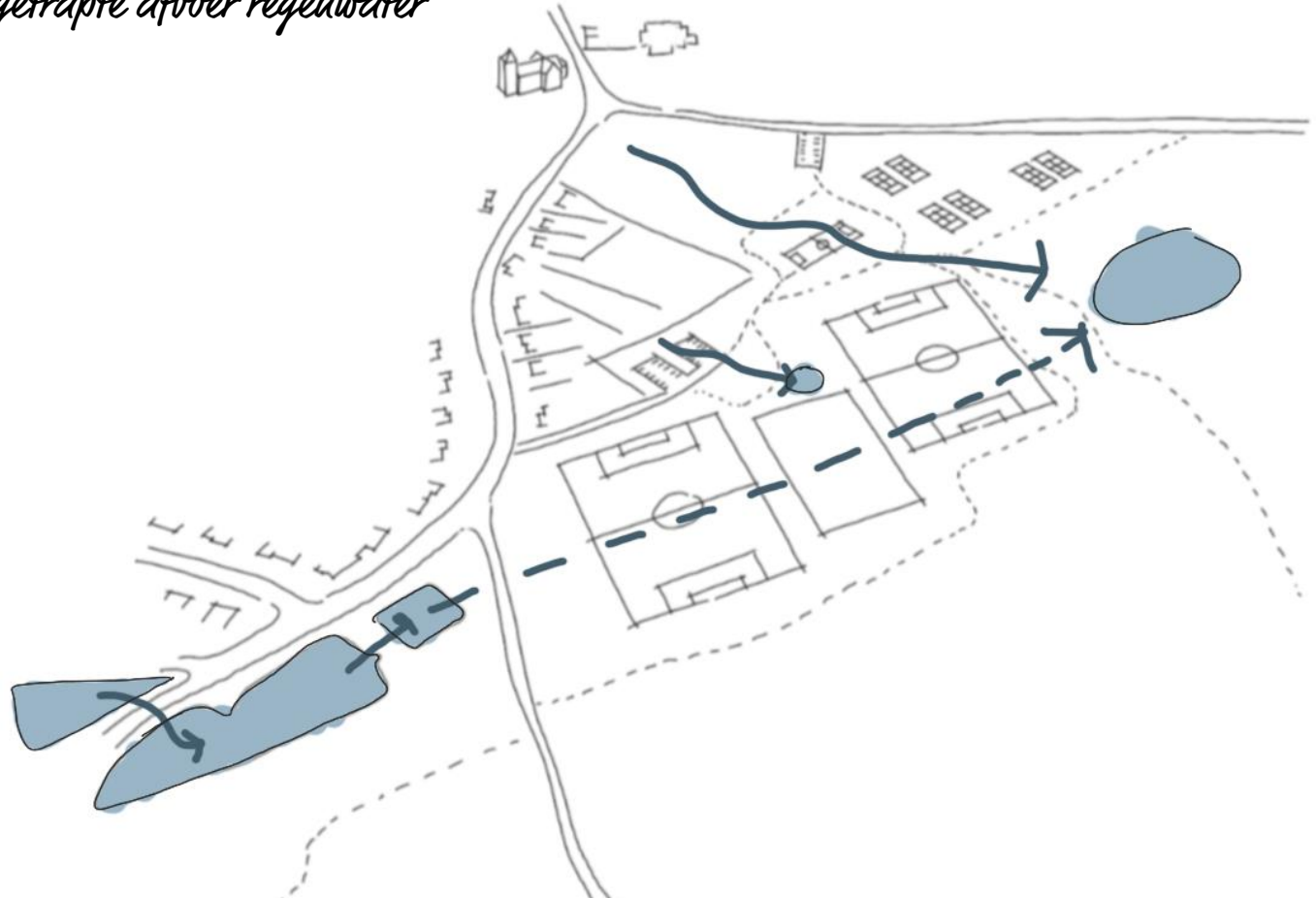

# Kaders inrichting gebied

*Paden hoofdrichtingen accentueren*

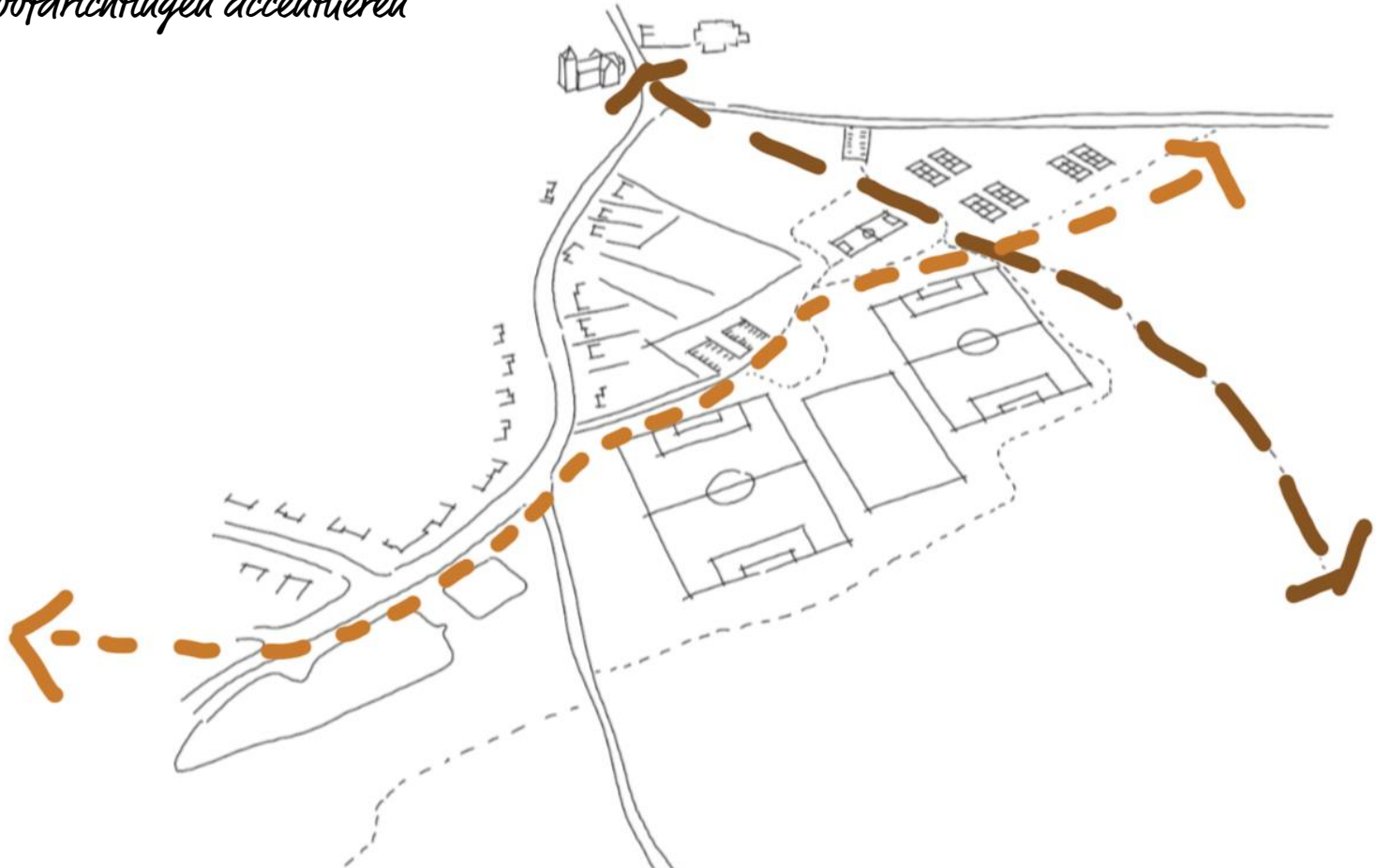

# Kaders inrichting gebied

*Fijnmazig padeenstructuur met sportelementen*





# Athletic Skills Model



# Inrichting

Voldoende zit-  
/rustelementen



Belevingsruimte sport –  
speelaanleidingen



Beweegrouten met  
natuurlijke  
beweegaanleidingen



Behouden en versterken  
groene uitstraling



Rekening houden met  
aanwezige natuurwaarden



Optimaliseren  
natuurwaarden en  
biodiversiteit



Prettige en veilige  
omgeving



Minimaliseren hekken –  
groen afscheiding



# Inrichting

## Sport

- Tennis1 baanblok all-weather
- Tennis1 baanblok gravel – renovatie
- 2 Jeu de Boule banen

## Bewegen

- Speelplaats kindcentrum (aansluiting met ASM)
  - 50% verhard, 50 % onverhard
- Terras met ingerichte speelplek kinderen
- ASM mogelijkheden over gehele terrein (sport en spel)

## Educatie

- Verhoogde groententuin
- Beleefbaar landschap en ruimte (water, boomgaard)





# Inrichting

## Verlichting

- Veilig en gericht
- Rekening houden met natuurwaarden
- Rekening houden met omwonenden
  
- 'Intensief deel' – conform openbare verlichting gemeente Voerendaal
- Extensief – Dynamisch of beperkt en gericht

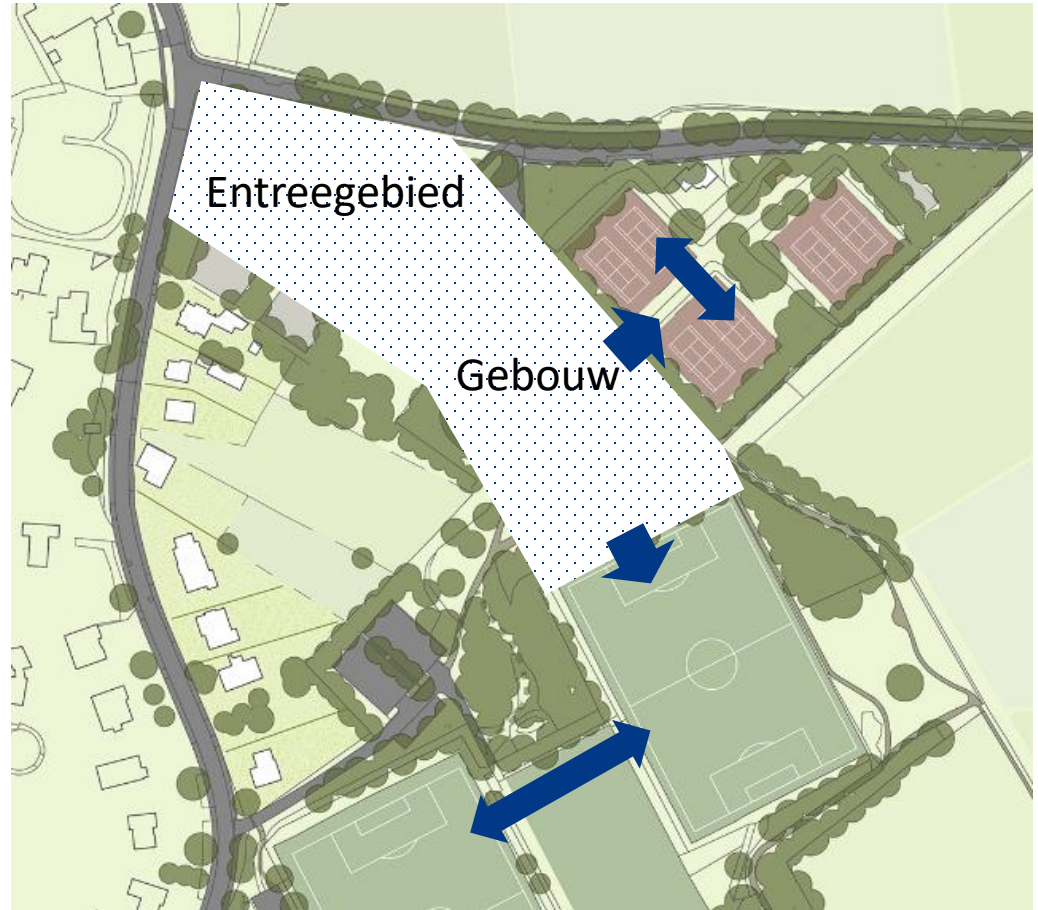

# Kaders groene centrale ontmoetingsruimte

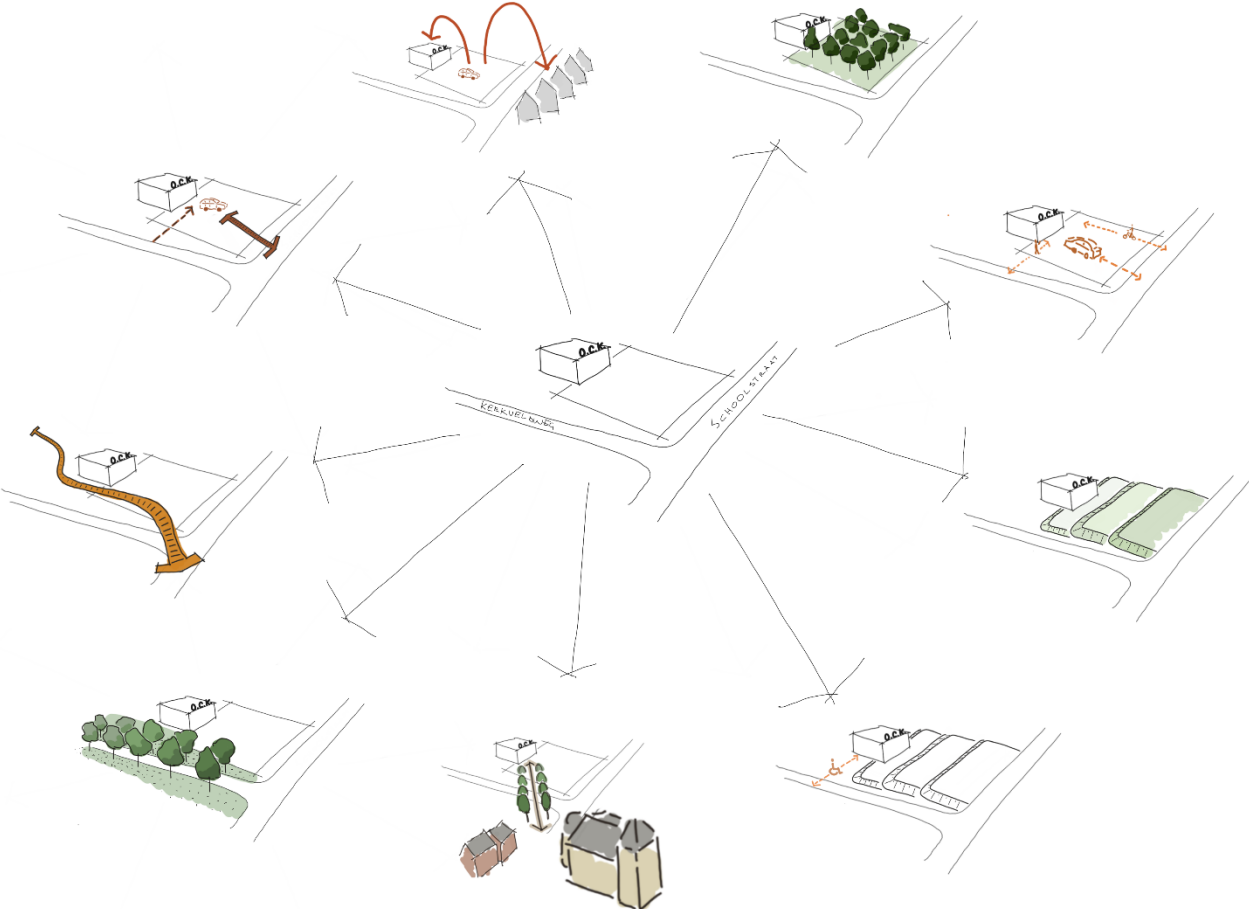

# Kaders groene centrale ontmoetingsruimte

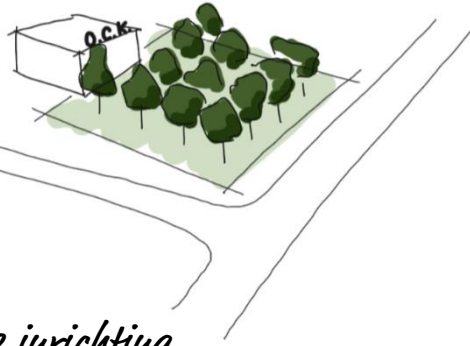

*Groene inrichting*

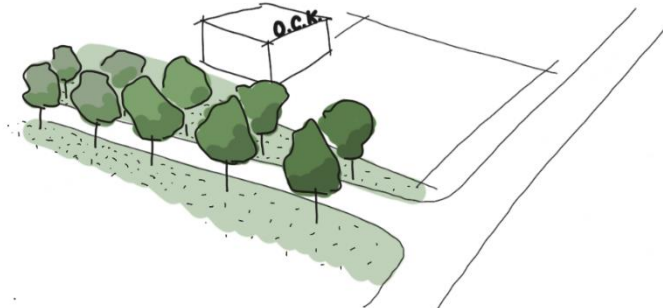

*Vergroenen Kerkveldweg*

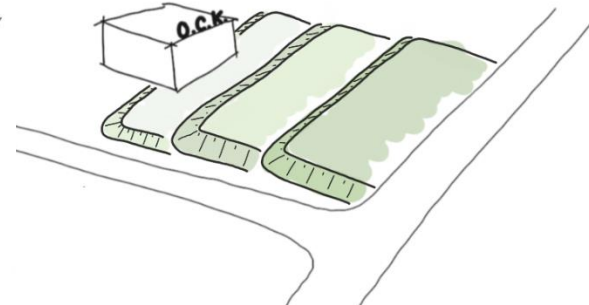

*Hoogteverschillen accentueren*

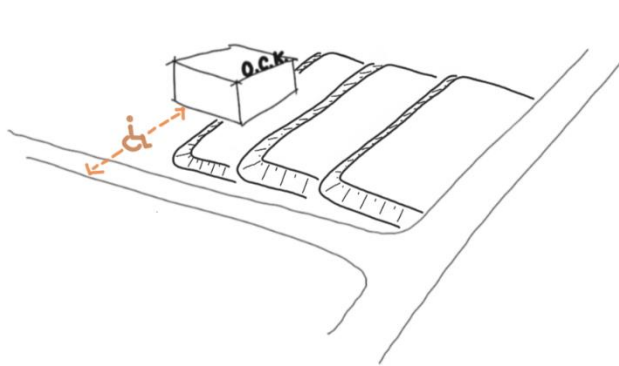

*Toegang minder validen*

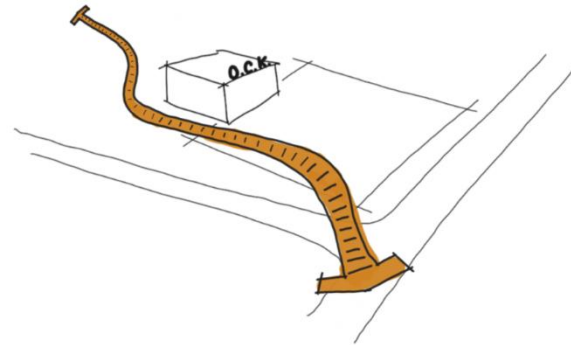

*Kerkepad zichtbaar maken*



*Visuele relatie met keru*

# Kaders groene centrale ontmoetingsruimte

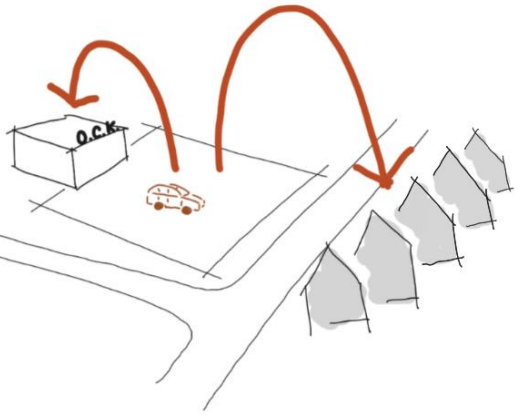

*Parkeren voor OCK en keru*

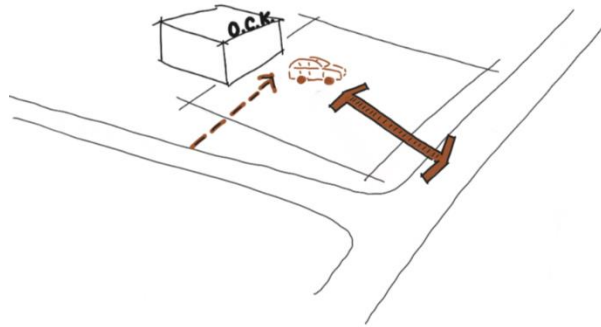

*Verkeersafwikkeling via Schoolstraat*

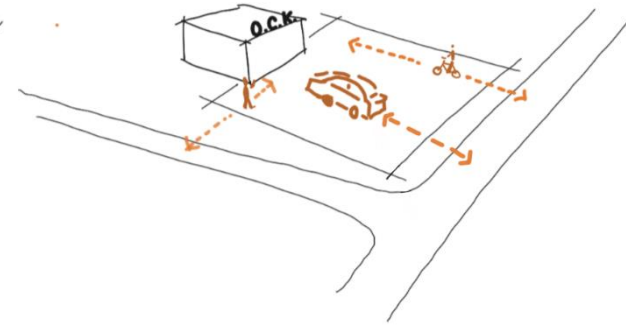

*Gescheiden verkeersstromen*

# Parkeren

Onderdeel	Ruimte benaming	Functie	Werkdag			zaterdag		zondag
			ochtend	middag	avond	middag	avond	middag
A. Kindcentrum	Basisschool	Basisschool	100%	100%	0%	0%	0%	0%
	Peuteropvang	Peuteropvang	100%	0%	0%	0%	0%	0%
	Buitenschoolse opvang	Buitenschoolse opvang	100%	100%	0%	0%	0%	0%
C. Gymzaal	Gymzaal/sportvloer	Sportzaal	0%	0%	100%	100%	100%	100%
D. Kantine/horeca/sociaal maatschappelijk	Bibliotheek	Bibliotheek	100%	100%	100%	100%	100%	100%
	Werkplek/kantoor Meander	Kantoor (zonder balie)	100%	100%	0%	0%	0%	0%
	Ontmoetingsruimte	Dorpscentrum	100%	100%	100%	100%	100%	100%
F. Sociaal ondernemerschap	Fysiotherapie	Fysiotherapie	100%	100%	100%	0%	0%	0%
	PUUR JONG	Consultatiebureau	100%	100%	0%	0%	0%	0%
Buitensporten	Tennisvereniging	Sportveld	25%	25%	50%	100%	25%	100%
	Voetbalvereniging	Sportveld	25%	25%	50%	100%	25%	100%

Parkeernormen CROW – voor basisschool en kinderdagverblijven  
afzonderlijke rekentool



# Parkeren

Ruimte benaming	Werkdag			zaterdag		zondag
	ochten	midda		midda		midda
	d	g	avond	g	avond	g
BSO	84,6	84,6	0,0	0,0	0,0	0,0
peuteropvang	7,5	0,0	0,0	0,0	0,0	0,0
buitenschoolse opvang	15,5	0,0	15,5	0,0	0,0	0,0
Gymzaal/sportvloer	0,0	0,0	30,8	30,8	30,8	30,8
Bibliotheek	0,9	0,9	0,9	0,9	0,9	0,9
werkplek/kantoor						
Meander	0,3	0,3	0,0	0,0	0,0	0,0
ontmoetingsruimte	38,4	38,4	38,4	38,4	38,4	38,4
Fysiotherapie	0,6	0,6	0,6	0,0	0,0	0,6
Puur jong	0,9	0,9	0,0	0,0	0,0	0,0
Tennisvereniging	4,0	4,0	7,9	15,9	4,0	15,9
Voetbalvereniging	31,8	31,8	63,5	127,0	31,8	127,0
	<b>185</b>	<b>162</b>	<b>158</b>	<b>213</b>	<b>106</b>	<b>214</b>



Onderdeel	Werkdag			zaterdag		zondag
	ochten	midda		midda		midda
	d	g	avond	g	avond	g
A. Kindcentrum	23,1	23,1	0,0	0,0	0,0	0,0
	3,3	0,0	0,0	0,0	0,0	0,0
	5,4	5,4	0,0	0,0	0,0	0,0
C. Gymzaal	0,0	0,0	21,9	21,9	21,9	21,9
D.	0,4	0,4	0,4	0,4	0,4	0,4
Kantine/horeca/sociaal maatschappelijk	0,6	0,6	0,0	0,0	0,0	0,0
	16,4	16,4	16,4	16,4	16,4	16,4
F. Sociaal ondernemerschap	2,0	2,0	2,0	0,0	0,0	0,0
	4,3	4,3	0,0	0,0	0,0	0,0
Buitensporten	1,3	1,3	2,6	5,2	1,3	5,2
	10,4	10,4	20,8	41,6	10,4	41,6
	<b>68</b>	<b>64</b>	<b>65</b>	<b>86</b>	<b>51</b>	<b>86</b>



# Kaders groene centrale ontmoetingsruimte

## Urichtingsstudie's

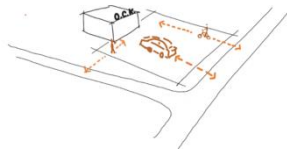
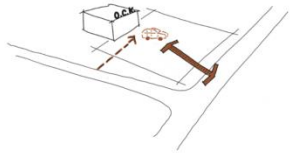
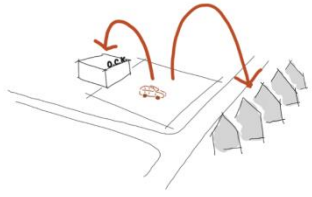

# Kaders centrale gebouw

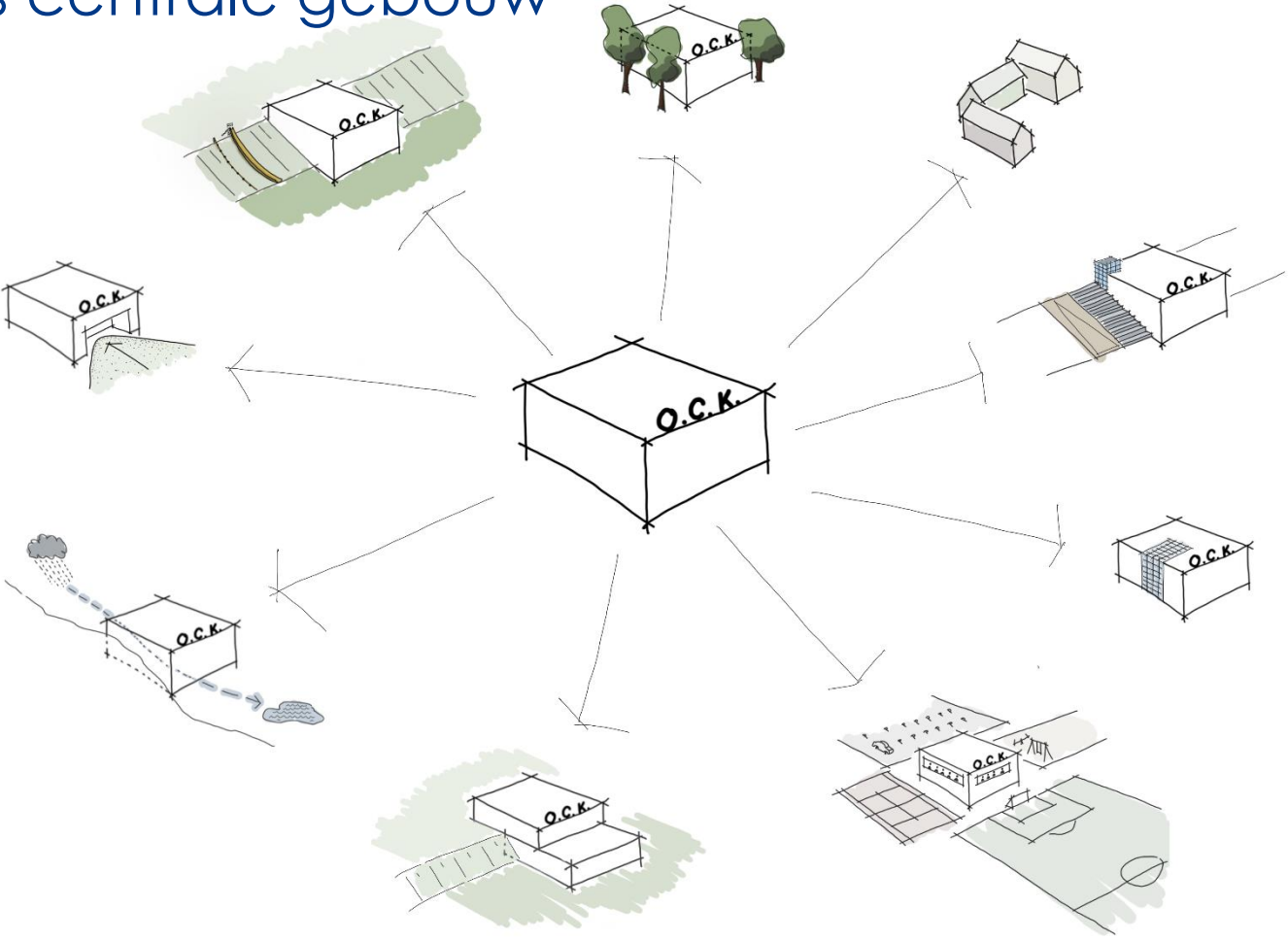

# Kaders centrale gebouw

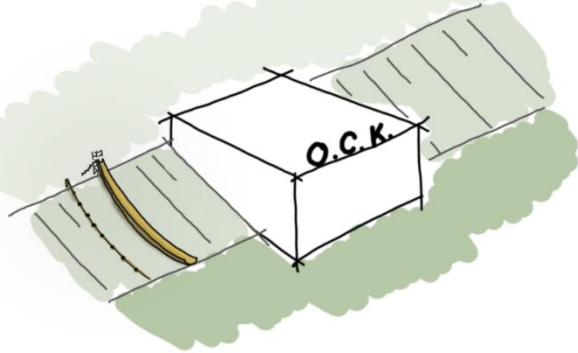

*Schuif het gebouw in het talud*

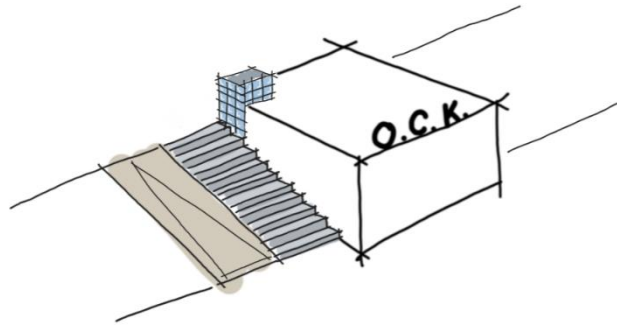

*Koppelen aan routes buiten*

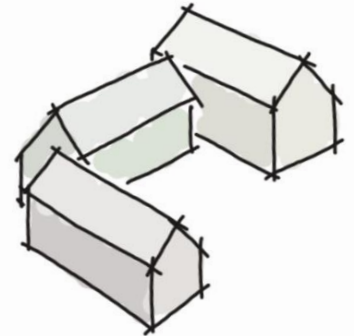

*Opdelen in kleine volumes*

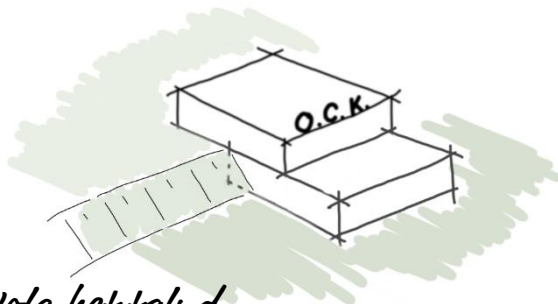

*Volg het talud*

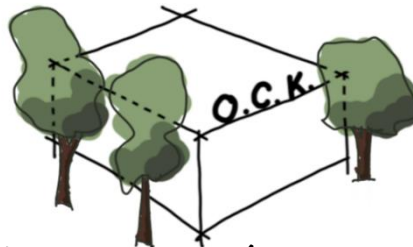

*Inpakken met levend groen*

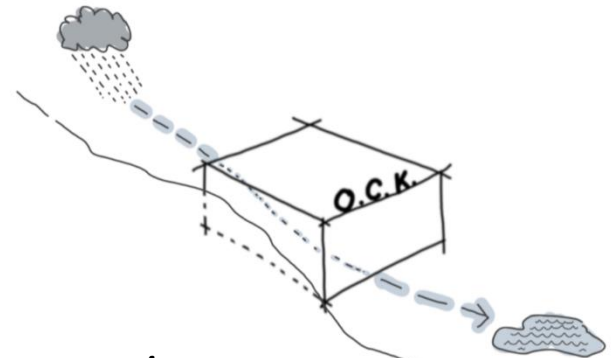

*Koppelen aan waterstructuur*

# Kaders centrale gebouw

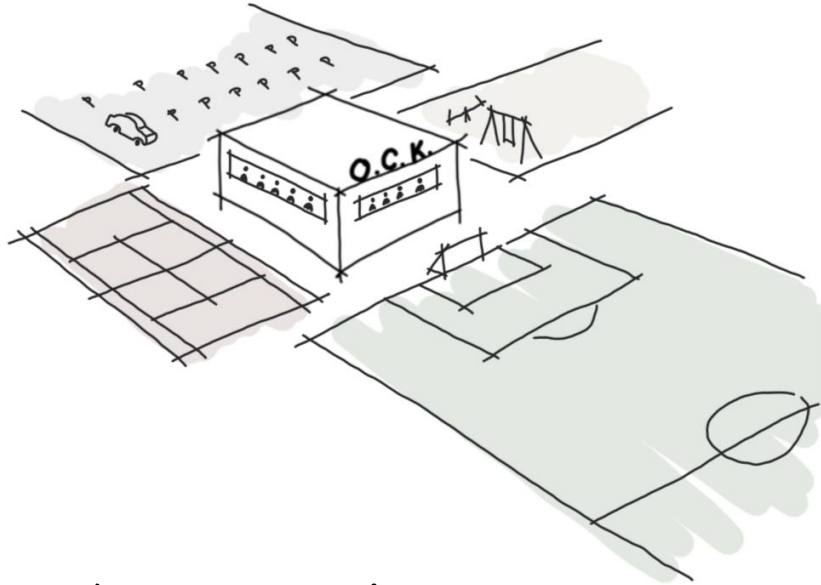

*Alzijdige oriëntatie gebouw*

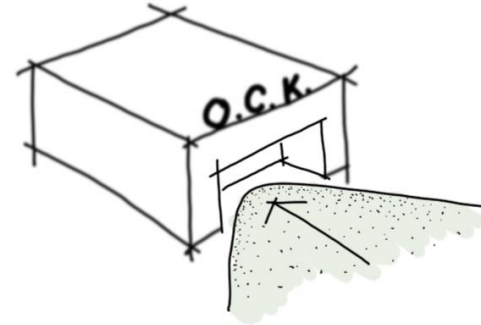

*Binnen met buiten verbinden*

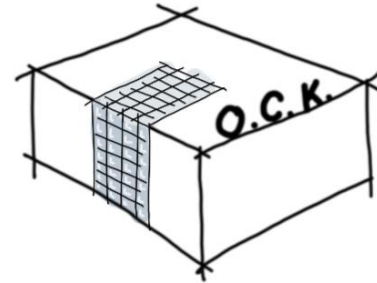

*Centrale ruimte verbindt verschillende functies*



# Kansen hoogwaardige inrichting





# Planning



# Planning

## *Open Club-Klimmen*



- Nov 2019: Ontwikkelplan gereed (Pve, Stiko, bouworg, kaders, SOK)
- Feb 2020: Raadsvergadering aanvullende besluitvorming
- Q1 2020: Aanbesteding integraal ontwerpteam
- Q2-4 2020: Schetsontwerp en Voorlopig Ontwerp
- Q1 2021: Aanbesteding aannemer
- Q2-4 2021: Start bouwteam, t/m uitvoeringsgereed ontwerp
- Q1 2022: Realisatiefase, na oplevering gebouw sloop school en afronden buitenruimte
- Q2 2023: Gehele plan gereed

